

4	No.	Revision	Date	Name
	△	PN Change from 1P-542-162	20/FEB/2014	S.J.PARK
	△			

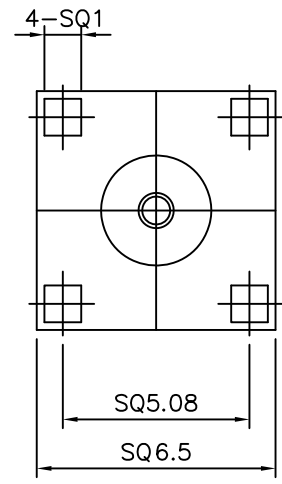
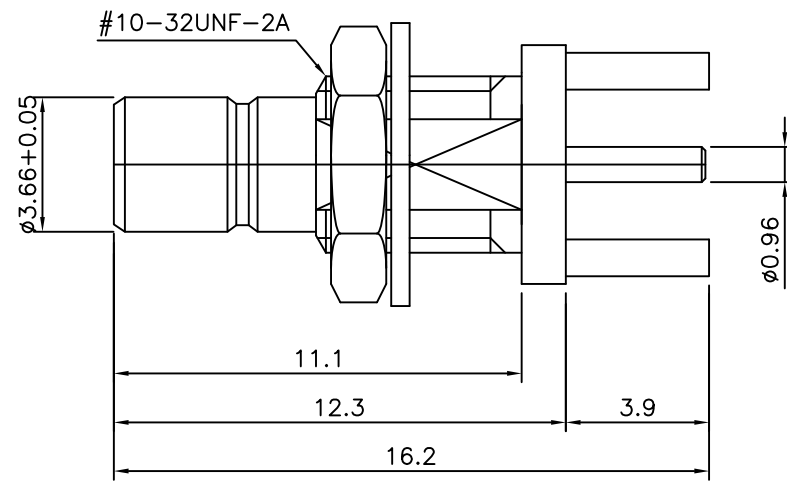
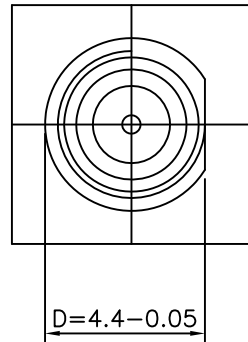

SMB Bulkhead Jack Receptacle
-PCB MOUNT

Connector parts	Materials	Finish
Body	Brass	Gold Plated
Center contact	Brass	Gold Plated
Nut & Washer	Brass	Gold Plated
Insulator	PTFE	-

NO.	DESCRIPTION	Q'TY	MATERIAL	FINISH	REMARKS.
PARTS No.	SMB-606-001		NAME	SMB-B/H-PCB JACK	APPROVED
MATERIAL	FINISH	TOLERANCES OTHERWISE SPEC. ±0.05		ANGLES ±1°	CHECKED
SCALE		UNIT	mm		DESIGNED S.J.LEE
DWG NO.		SMB-606-001		DATE.	2003/8/19

CUSTOMER

