

4	5	6	
No.	Revision	Date	Name
△	PN Change from 1B-314-00	12/12/2013	B.G.YUN
△			

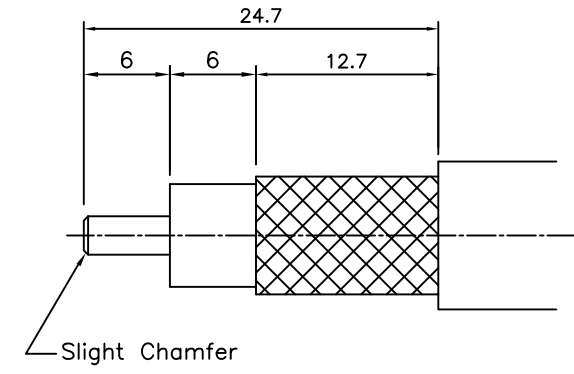
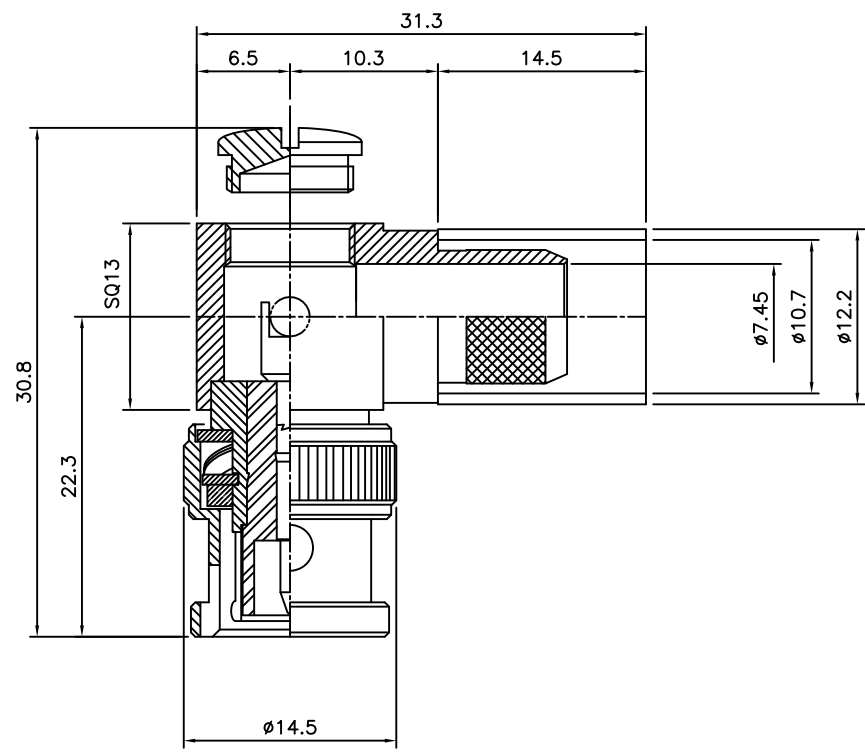

Recommended Stripping DIM'S

Recommended Crimp DIES : HEX10.7

BNC Right Angle PLUG
For CABLE LMR400,RG8

Connector parts	Materials	Finish
Coupling Cap	Zinc	Nickel Plated
Body	Brass	Nickel Plated
Center contact	Brass	Gold Plated
Insulator	TEFLON	-
Ferrule	Brass	Nickel Plated
Gasket	Silicone rubber	-

CUSTOMER

NO.	DESCRIPTION	Q'TY	MATERIAL	FINISH	REMARKS.
PARTS No.	BNC-314-001		NAME	BNC-LP-LMR400	APPROVED
MATERIAL	FINISH	TOLERANCES OTHERWISE SPEC. ±0.05		ANGLES ±1°	CHECKED
		SCALE	UNIT mm		DESIGNED S.J.LEE
		DWG NO.	BNC-314-001		DATE. 21/NOV/2006

