

4	No.	Revision	Date	Name
	△	PN Change from 1B-321-00	09/APR/2014	S.J.PARK
	△			

D
C
B
A

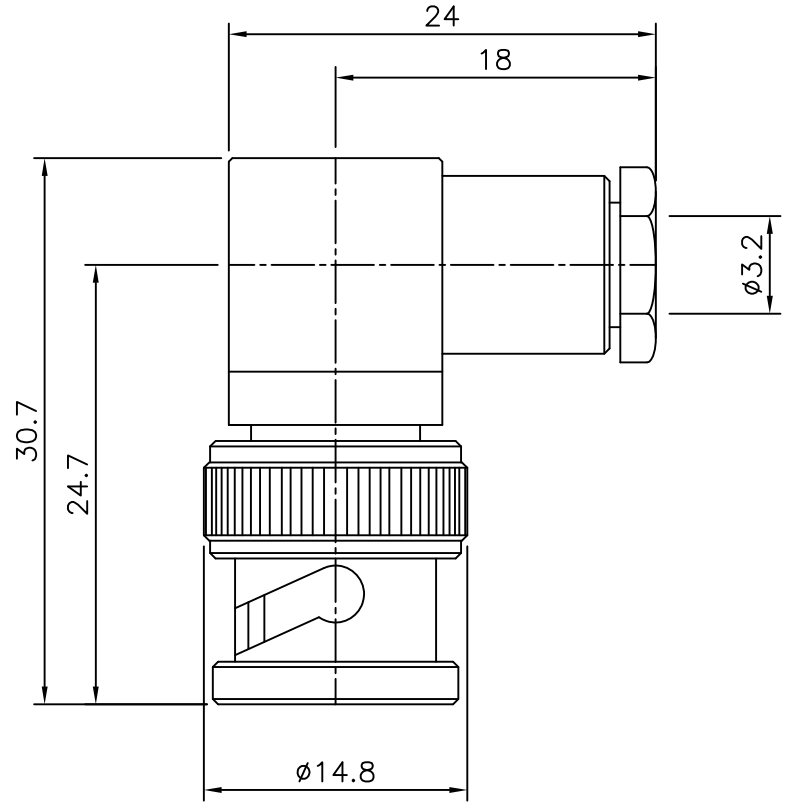

Connector parts	Materials	Finish
Coupling Cap	Brass	Nickel Plated
Body	Brass	Nickel Plated
Center contact	Brass	Gold Plated
Ferrule	Brass	Nickel Plated
Insulator	PTFE	-

BNC-Right angle-PLUG
for Cable-RG316 CLAMP

CUSTOMER

NO.	DESCRIPTION	Q'TY	MATERIAL	FINISH	REMARKS.
PARTS No.	BNC-311-002		NAME	BNC-LP-316 CLAMP	APPROVED
MATERIAL	FINISH	TOLERANCES OTHERWISE SPEC. ± 0.05		ANGLES $\pm 1^\circ$	CHECKED
		SCALE	UNIT mm		DESIGNED S.J.LEE
		DWG NO. BNC-311-002		DATE. 2001.05/07	

